

## Tag-it™ HF TRANSPONDER INLAYS SQUARE RECTANGLE

### FEATURES

- 13.56 MHz Operating Frequency
- 256 Bit User Memory in 8 × 32-bit Blocks
- User and Factory Lock per Block
- Simultaneous Identification (Anti-collision)

### APPLICATIONS

- Library Applications
- Product Authentication
- Ticketing
- Stored Value

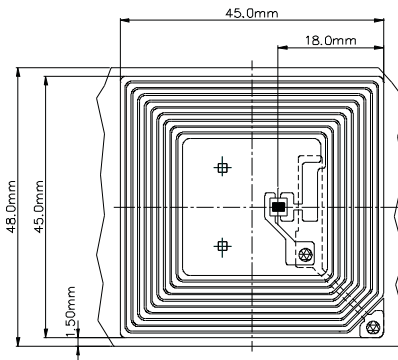

### DESCRIPTION

Texas Instruments' Tag-it™ HF Transponder Inlays are the first generation of 'smart' inlays consist of 13.56 MHz high frequency (HF) transponders. These products offer a user accessible memory of 256 bits, organized in 8 blocks available in three different antenna shapes with frequency offset for integration into paper, PVC or other substrates.

Tag-it HF Transponder Inlays are manufactured with TI's patented laser tuning process to provide consistent read performance. And prior to delivery, the transponders undergo complete functional and parametric testing in order to provide the high quality that customers have come to expect from TI.

The Tag-it HF Transponder Inlays are well suited for a variety of applications including but not limited to: product authentication, library applications, supply chain management, asset management, and ticketing/stored value applications.

### ORDERING INFORMATION

PACKAGE <sup>(1)</sup>	
Typical quantity of good units per reel	5,000

(1) Package drawings, standard packing quantities, thermal data, symbolization, and PCB design guidelines are available at [www.ti.com/sc/package](http://www.ti.com/sc/package).



Please be aware that an important notice concerning availability, standard warranty, and use in critical applications of Texas Instruments semiconductor products and disclaimers thereto appears at the end of this data sheet.

Tag-it is a trademark of Texas Instruments.

**ABSOLUTE MAXIMUM RATINGS**

over operating free-air temperature range (unless otherwise noted)

	VALUE	UNIT
Operating Temperature	–25 to +70	°C
Storage Temperature (single inlay)	–40 to +85 (warpage may occur at upper temperature range)	°C
Storage temperature (on reel)	–40 to +40	°C

**OPERATING CHARACTERISTICS**

over operating free-air temperature range (unless otherwise noted)

PARAMETER	PART NUMBER	UNIT
	RI-I110A-01	
Recommended Operating frequency	13.56	MHz
Passive Resonance Frequency (at +25°C)	14.26 MHz ± 400 kHz (includes frequency offset to compensate further integration into paper or PVC lamination; drops down to operating frequency when exposed to activation field strength)	
Typ. required activation field strength to read (at +25°C)	103 dB $\mu$ A/m <sup>(1)</sup>	
Typ. required activation field strength to write (at +25°C)	108 dB $\mu$ A/m <sup>(1)</sup>	
Factory programmed Read Only Number	32 bits	
Memory (user programmable)	256 bits organized in 8 × 32-bit blocks	
Uplink / downlink data rates	26.7 kBd / 6.2 and 9 kBd	
Typical programming cycles (at +25°C)	100,000	
Data retention time (at +55°C)	> 10 years	
Simultaneous Identification of Tags	Up to 50 tags per second (reader/antenna dependent)	
Antenna size	45 mm × 45mm (~1.77 in × ~1.77 in)	
Foil width	48 mm ± 0.5 mm (1.89 in ± 0.02 in)	
Foil pitch	50.8 mm +0.1mm/–0.4mm (~3.78 in)	
Base material	Substrate: PET (Polyethylenetherephtalate) Antenna: Aluminum	
Delivery	Single row tape wound on cardboard reel with 500 mm diameter Reel outer width: approx. 60 mm (~2.36 in) Reel inner width: approx. 50 mm (~1.97 in) Hub diameter: 76.2 mm (3 in)	

(1) After integration into paper or PVC Lamination

**SUPPORTED COMMAND SET**

REQUEST	ADDRESSED	NON-ADDRESSED
Get_Version	√	√
Get_Block	√	√
Put_Block	√	√
Put&Lock_Block	√	√
Lock_Block	√	√
SID_Poll		√
Quiet	√	√

√ : Implementaed  
 – : Not applicable

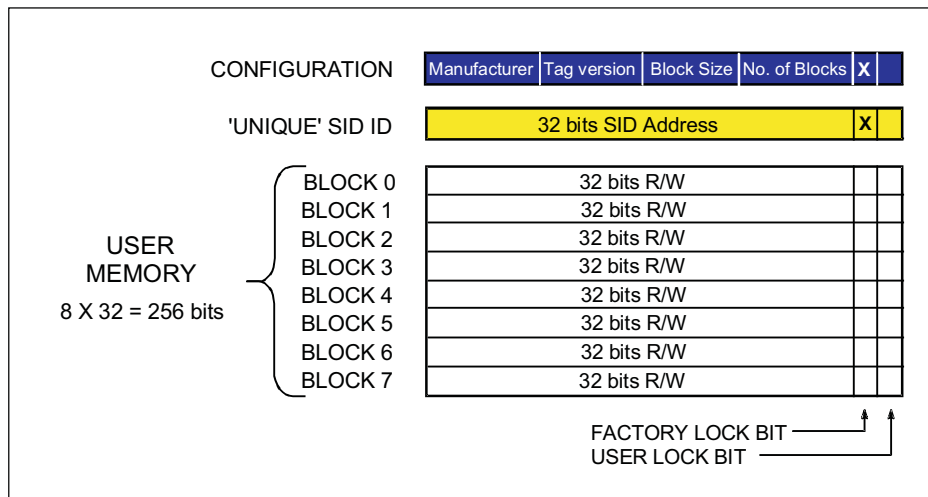

**Figure 1. Memory Organization**

## IMPORTANT NOTICE

Texas Instruments Incorporated and its subsidiaries (TI) reserve the right to make corrections, modifications, enhancements, improvements, and other changes to its products and services at any time and to discontinue any product or service without notice. Customers should obtain the latest relevant information before placing orders and should verify that such information is current and complete. All products are sold subject to TI's terms and conditions of sale supplied at the time of order acknowledgment.

TI warrants performance of its hardware products to the specifications applicable at the time of sale in accordance with TI's standard warranty. Testing and other quality control techniques are used to the extent TI deems necessary to support this warranty. Except where mandated by government requirements, testing of all parameters of each product is not necessarily performed.

TI assumes no liability for applications assistance or customer product design. Customers are responsible for their products and applications using TI components. To minimize the risks associated with customer products and applications, customers should provide adequate design and operating safeguards.

TI does not warrant or represent that any license, either express or implied, is granted under any TI patent right, copyright, mask work right, or other TI intellectual property right relating to any combination, machine, or process in which TI products or services are used. Information published by TI regarding third-party products or services does not constitute a license from TI to use such products or services or a warranty or endorsement thereof. Use of such information may require a license from a third party under the patents or other intellectual property of the third party, or a license from TI under the patents or other intellectual property of TI.

Reproduction of information in TI data books or data sheets is permissible only if reproduction is without alteration and is accompanied by all associated warranties, conditions, limitations, and notices. Reproduction of this information with alteration is an unfair and deceptive business practice. TI is not responsible or liable for such altered documentation.

Resale of TI products or services with statements different from or beyond the parameters stated by TI for that product or service voids all express and any implied warranties for the associated TI product or service and is an unfair and deceptive business practice. TI is not responsible or liable for any such statements.

Following are URLs where you can obtain information on other Texas Instruments products and application solutions:

### Products

Amplifiers	<a href="http://amplifier.ti.com">amplifier.ti.com</a>
Data Converters	<a href="http://dataconverter.ti.com">dataconverter.ti.com</a>
DSP	<a href="http://dsp.ti.com">dsp.ti.com</a>
Interface	<a href="http://interface.ti.com">interface.ti.com</a>
Logic	<a href="http://logic.ti.com">logic.ti.com</a>
Power Mgmt	<a href="http://power.ti.com">power.ti.com</a>
Microcontrollers	<a href="http://microcontroller.ti.com">microcontroller.ti.com</a>
Low Power Wireless	<a href="http://www.ti.com/lpw">www.ti.com/lpw</a>

### Applications

Audio	<a href="http://www.ti.com/audio">www.ti.com/audio</a>
Automotive	<a href="http://www.ti.com/automotive">www.ti.com/automotive</a>
Broadband	<a href="http://www.ti.com/broadband">www.ti.com/broadband</a>
Digital Control	<a href="http://www.ti.com/digitalcontrol">www.ti.com/digitalcontrol</a>
Military	<a href="http://www.ti.com/military">www.ti.com/military</a>
Optical Networking	<a href="http://www.ti.com/opticalnetwork">www.ti.com/opticalnetwork</a>
Security	<a href="http://www.ti.com/security">www.ti.com/security</a>
Telephony	<a href="http://www.ti.com/telephony">www.ti.com/telephony</a>
Video & Imaging	<a href="http://www.ti.com/video">www.ti.com/video</a>
Wireless	<a href="http://www.ti.com/wireless">www.ti.com/wireless</a>

Mailing Address: Texas Instruments  
Post Office Box 655303 Dallas, Texas 75265